

# SGA23 OZONE / OXYGEN SYSTEM

The SGA23 delivers the power of ozone generators many times its size. Producing more than 2.4 lbs./day, a high concentration, air-cooled ozone generator is combined with an onboard oxygen concentrator in an attractive, compact, wall-mountable stainless steel housing.

The powerful SGA23 is easy to operate with a convenient, intuitive control panel. To easily manage the ozone generating process, it offers: 0-100% variable power control, feed gas control, inlet air pressure and reactor back-pressure gauges, power supply feed back reference meter, and LED ozone production indicator. The control interface includes an optional 0-10VDC or 4-20mA input signal for 0-100% variable ozone concentration control.

A highly efficient, reliable ceramic/titanium reactor cell uses our exclusive Floating Plate Technology™ and is powered by an advanced, high-frequency pulse modulated variable control power supply. Responsive, accurate ozone output control is assured by instantaneous amplitude modulation and the proven stability of our Floating Plate Technology™ reactor cell design.

The SGA23 Ozone Generator is engineered to meet all of the ozone process requirements found in the most demanding applications; yet it is easy to install, simple to operate, and will provide years of trouble-free operation.



## THE SGA23

### FEATURES

- Stainless Steel Wall Mountable Enclosure
- Air-Cooled Ceramic and Titanium Reactor Cell
- Onboard Oxygen Concentrator
- 5-Micron Filter/Regulator with Auto Drain
- Over Temperature Control
- Feed Gas Flow Switch

### CONTROLS

- Variable Output Control 0-100%
- Power Feed Back Reference Meter 0-5VDC
- Reactor Pressure Gauge 0-15 psi
- Air Input Pressure Gauge 0-30 psi
- Feed Gas Flow Control 0-30scfh
- LED Visual Ozone Indicator
- On/Off Lighted Circuit Breaker

# SGA23 OZONE / OXYGEN SYSTEM

Product Description Integrated Ozone/Oxygen Generation System

Part Number R-SGA231 115V model  
R-SGA232 230V model

## SPECIFICATIONS

Ozone Production	45 g/hr - 2.4 lbs./day
Oxygen Feed Gas Flow	30 scfh
Ozone Concentration	4%-8% %/wt
Max Reactor Pressure	15 psi
Compressed Air Requirement	9 scfm
Compressed Air Pressure	20 psi
Feed Gas Flow Range	0-30 scfh
Variable Control	0-100 %
Power Consumption	450 watts
Consumption w/ Compressor	2930 watts
Power Supply Fuse	8 ampere
On/Off Breaker	15 ampere
Air Cooling	240 scfm
Compressed Air Inlet Fitting	1/4" fnpt
Ozone Outlet	1/4" tube
Power Requirement	115v 60Hz or 230v 50/60Hz 1 phase
Height	22 inches
Width	26 inches
Depth	11 inches
Weight	110 lbs

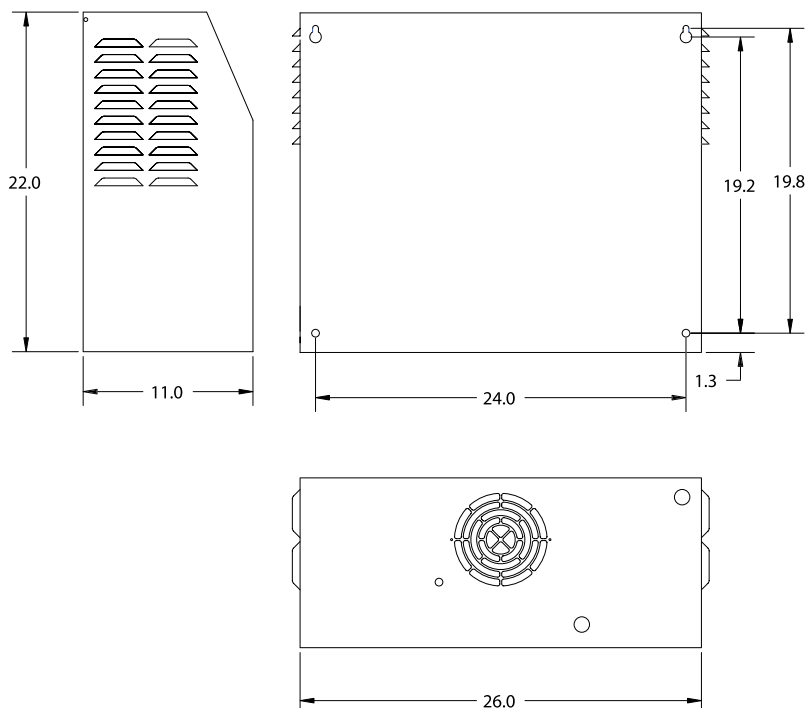

## THE SGA23

### OPTIONS

Oil-less Compressor Kit 9 scfm @ 20 psi  
Coalescing Filter  
Replacement Filter Elements

An optional oil-less compressor kit is available to provide for the compressed air requirement. If plant air or other source is used the optional coalescing filter is required. See SGA air requirements for important compressed air quality requirements.



**EQUIPOS ESPECIALIZADOS DEL ATLANTICO SA de CV**

PASEO LOMAS DE ROSALES #307 COL. LOMAS DE ROSALES C.P. 89100 TAMPICO, TAM. MÉXICO

TEL. - (833) 116-54-10

www.eatlantico.com

e-mail: marte.alvarez@atlantico.com